

NON-RETRACTABLE TWISTLOCK Type BLR 149/2NR

The range of Twistlocks has been designed to secure ISO and special containers to rigid vehicles, trailer chassis and rail wagons in environmental conditions ranging from tropical to sub-zero.

This Twistlock offers the user the following important advantages.:

- Simply fitted to vehicle/chassis, usually by welding.
- Weldable cast steel body and forged steel stem to ensure rugged strength and durability.
- Securing head remains permanently proud of the deck for loading containers in the shortest possible time.

NB not recommended for tipping applications See BLR 149 NRS 3HTS.

OPERATIONAL PROCEDURE TO LOCK

Twistlock in load position without container, handle facing outward.

1. Load container onto vehicle.
2. Turn handle 90° in either direction until index is engaged.

TO UNLOCK

1. Turn handle 90° until index is engaged and handle is facing outward.
2. Remove container from vehicle.
3. Turn handle 90° to left or right.

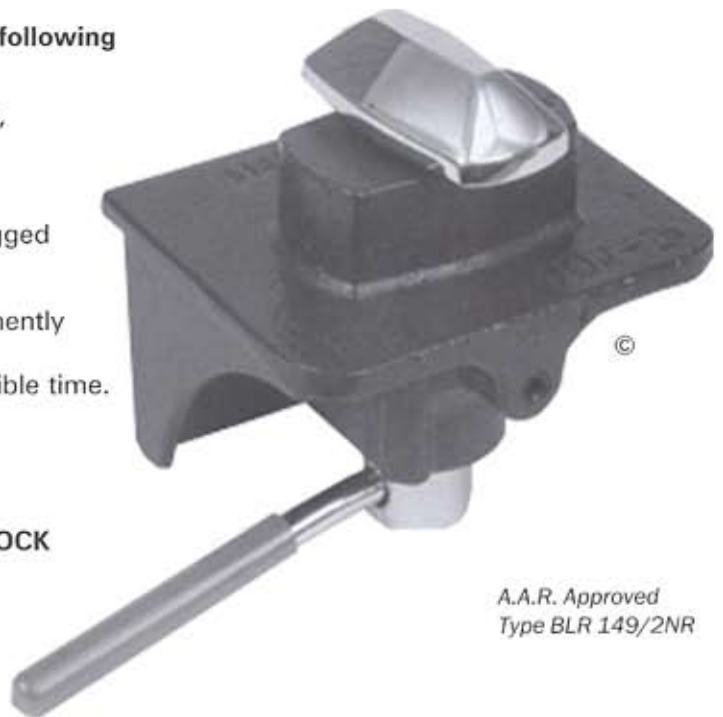

A.A.R. Approved
Type BLR 149/2NR

NON-RETRACTABLE TWISTLOCK Type BLR 149/2NR

TECHNICAL INFORMATION

ITEM	DESCRIPTION	QTY	TWISTLOCK ASSEMBLY	
			ROUND HANDLE	FLAT HANDLE
1	BODY	1	BLR 1066	BLR 1066
2	STEM	1	BLR 1067	BLR 1068
3	COLLAR	1	BLR 987	-
4	HANDLE	1	BLR 988	BLR 1026
5	SLEEVE	1	BLR 989	BLR 1031
6	STEEL BALL	1	BLR 1236	BLR 1236
7	SPRING	1	BLR 990/2	BLR 990/2
8	GRUB SCREW	1	BLR 1237	BLR 1237

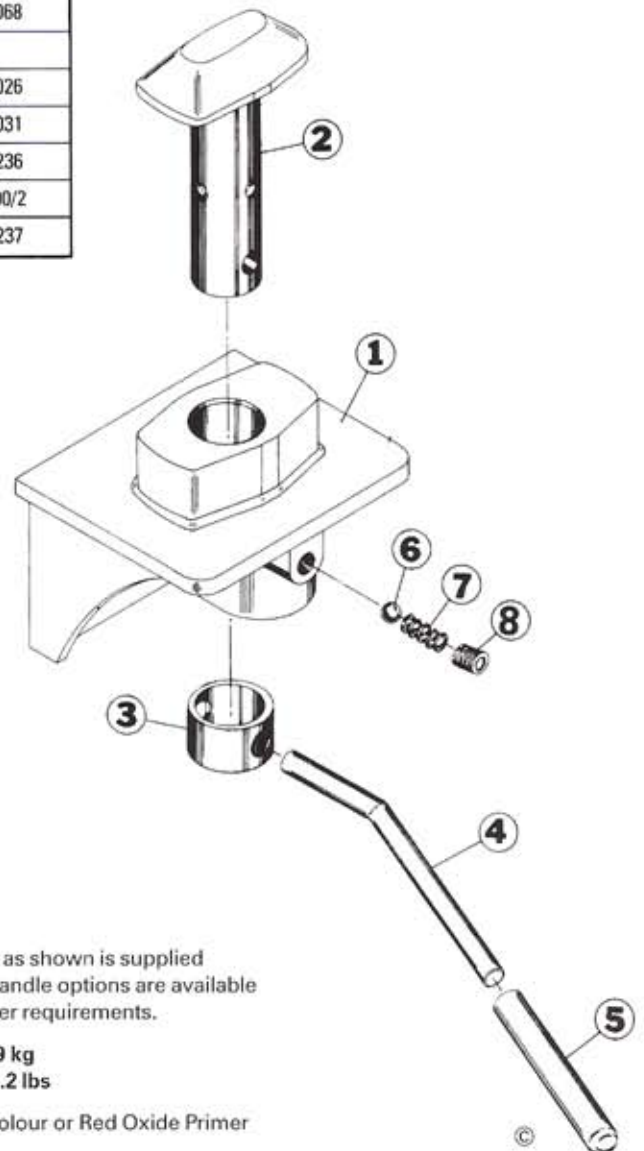
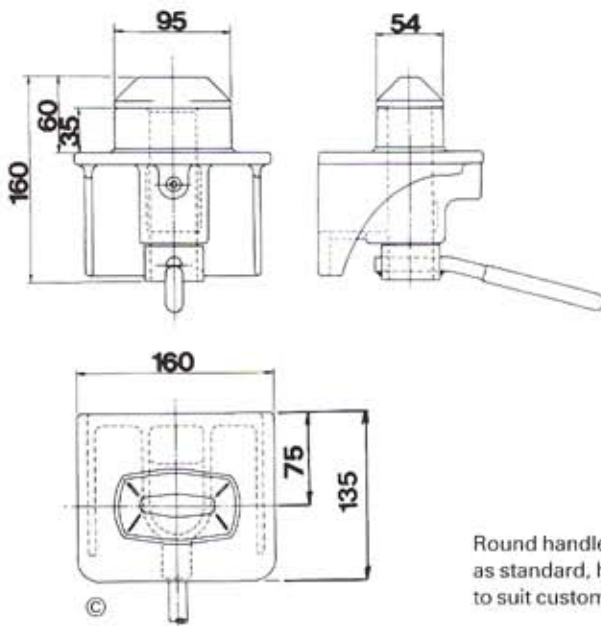

Round handle as shown is supplied as standard, handle options are available to suit customer requirements.

WEIGHT: 6.9 kg
15.2 lbs

FINISH: Self colour or Red Oxide Primer